

ax8



bx8



cx2

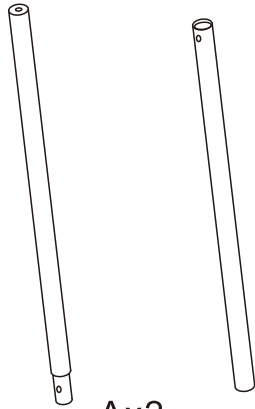

Ax2

Bx2

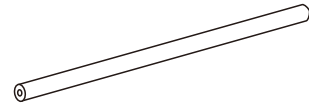

Dx4



Cx4

1

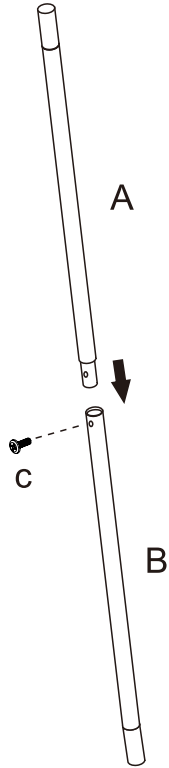
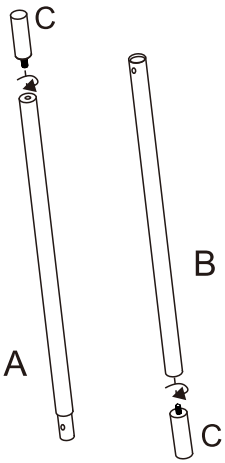

2

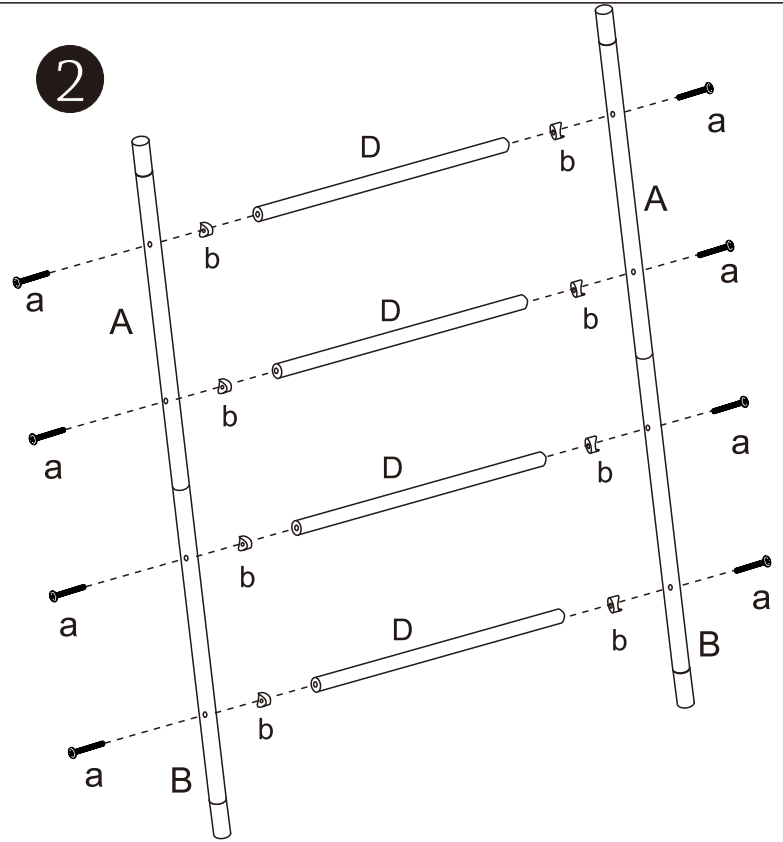

3

